

GES ENERGY S GES ENERGY M

PASSIVE VENTILATION WITH WIRING
DIAGRAM FOR OPTIMA 100 AND
OPTI MA 250

INSTALLATION MANUAL

UK / Version 13.01.2015



Table of contents

GES Energy - Installation	4
Mounting.....	5
Duct connection.....	6
Condensate drain	6
Duct system.....	7
Insulation of ducts in cold loft spaces	7
Insulation of ducts in warm spaces.....	8
Reheating of supply air.....	8
Electrical connection.....	9
Inspection and commissioning of the appliance	9
Optimum commissioning of the appliance.....	9
Maintenance of the appliance.....	10
Fault finding	12
PCB and Wiring Diagrams.....	13
EU-Declaration of conformity.....	16

■ **IMPORTANT** ■ **IMPORTANT** ■ **IMPORTANT** ■ **IMPORTANT** ■ **IMPORTANT** ■

When installing the GES Energy follow these instructions:

- 1) Turn off the electricity before opening the unit
- 2) Install an air tight water trap on a non-freezing location to compensate for the fan pressure.
- 3) The height of the water trap **must be** at least 50 mm.
- 4) Make sure that the drain flows downwards all the way from the unit.
- 5) Pour 1 liter water into the drip tray of the unit to verify that it is drained properly. Before each heating season make sure that the drain is filled with water.
- 6) If freezing of the water trap occurs, it is necessary to install a thermostat and electrical heater to prevent freezing when the temperature drops below +2 °C.
- 7) Air flow adjustments must be made on both supply and exhaust air sides before use of the machine. It is important supply and exhaust air volumes are balanced.
- 8) It is recommended to keep the ducts closed until the unit is started and the system is adjusted.

This instruction must be followed. If the condensate drain is not made according to this instruction, GENVEX A/S can not be made responsible for any additional damages, which have nothing to do with the GENVEX unit.

■ **IMPORTANT** ■ **IMPORTANT** ■ **IMPORTANT** ■ **IMPORTANT** ■ **IMPORTANT** ■



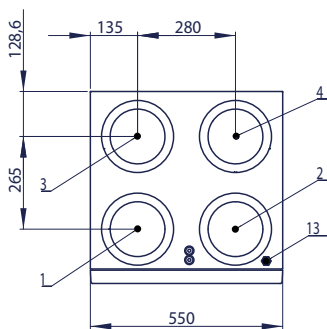
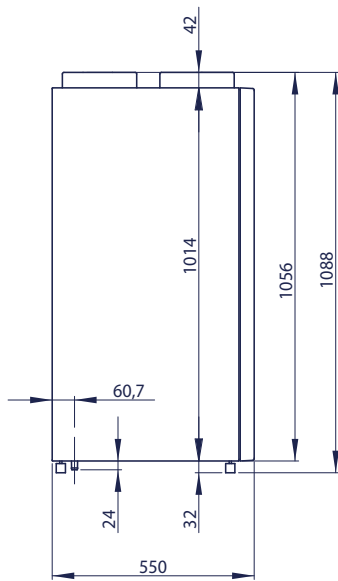
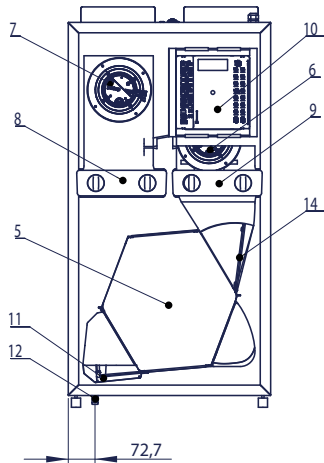

- | | |
|-----------------------------------|-----------------------------|
| 1: Fresh air | 8: Fresh air filter |
| 2: Extract air | 9: Extract air filter |
| 3: Exhaust air | 10: Electrical box |
| 4: Supply air | 11: Condensate tray |
| 5: Counter current heat exchanger | 12: Condensate drain/outlet |
| 6: Supply air fan | 13: 230V/50Hz |
| 7: Extract air fan | 14: By-pass (Option) |

GES Energy 1 - Installation

The GES Energy 1 is supplied in a vertical version (as shown) or a horizontal version.

The vertical version cannot be used as a horizontal version and vice versa. One of the reasons being that the condensate water would not reach the condensate drain if the unit would be turned around.

The unit must be positioned so that the condensate drain with a necessary trap can be properly led to an internal drain. In the winter period a unit may produce up to 6 litres of condensate water per day. To allow access for service and maintenance, there must be a clear space of a minimum of 600 mm in front of the unit.

Weight: 32 kg



The vertical version cannot be used as a horizontal version and vice versa. One of the reasons being that the condensate water would not reach the condensate drain if the unit would be turned around.

invisible wall mounts

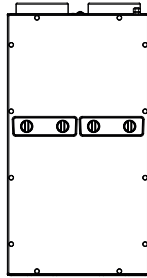
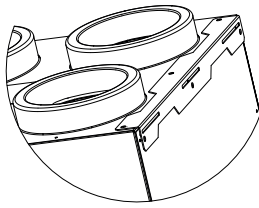

Visible wall mounts

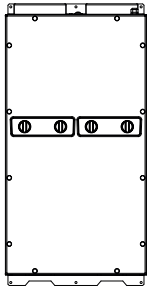
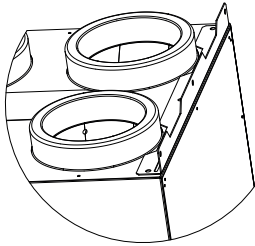

Closet mounting



Laying Mounting

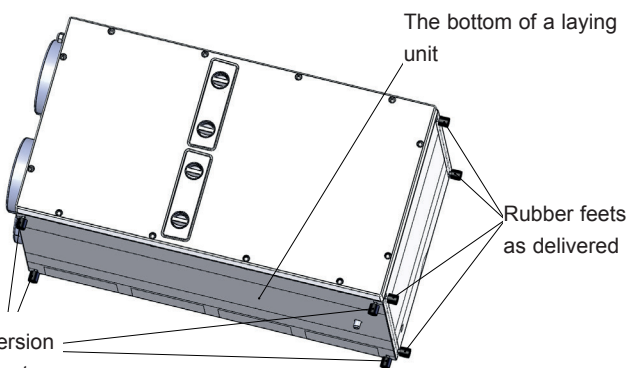

By a laying version the rubber feet have to be placed here

Mounting

GES Energy is supplied with an universal wall mounting kit.

Wall mounting (vertical)

GES Energy can be mounted directly on the wall with visible or invisible wall mounts.

Closet mounting (vertical)

GES Energy is created to fit into a closet with (60 x 60 cm) as shown. You can place the unit on the universal mounting kit as shown.

Horizontal Mounting

GES Energy is always supplied with rubber feet mounted like on the vertical version. By horizontal version it is necessary to remove the rubber feet and place them on the left site of the unit (the bottom).

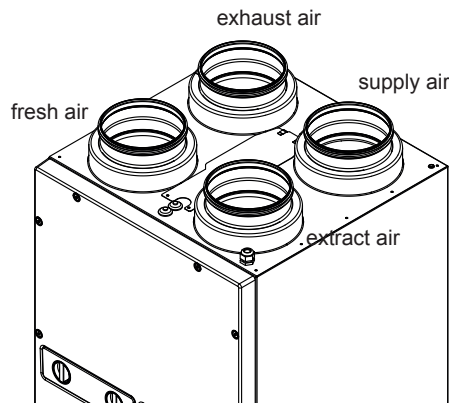

Standing GES Energy

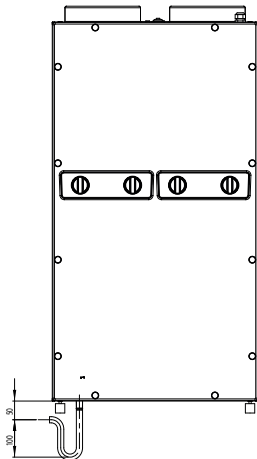

Laying GES Energy

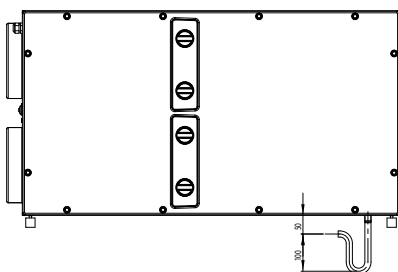

No water in the siphon = water damage

Duct connection

All duct connections are with a yellow sticker indicating the type of ventilation pipe to be connected.

Connect the supply air  :

Duct system from the unit to the supply outlet in the living area.

Connect the extract air  :

Duct system from wet rooms to the unit.

Connect the fresh air  :

Duct system from fresh air roof cowls/external grills from or the ground collector to the unit.

Connect the exhaust air  :

Duct system from unit to the escaping roof cowls/external grills.



Optimal operation is achieved by mounting a connector piece \varnothing 160 mm in each outlet of the GES Energy and tighten them with the supplied collar bands.

Condensate drain

The units produce up to 6 litres of condensate per day. It is therefore important that the condensate drain is correctly executed and that the unit has a slight fall towards the condensate drain.

The condensate drain pipe must be air tight for example by bending a copper pipe as an siphon (see sketch to the left). Use an armed water hose between the drain connecting piece on the unit and the siphon and tightend it in both ends with a collar band.

From the siphon and to the internal outlet there must be a necessary fall on 1%. The condensate drain must be fitted with a water trap as there is negative pressure in the chamber in which the condensate tray is mounted.

If the unit is installed in a cold loft space, the condensate drain pipe must be insulated to prevent freezing of the condensate in the pipe. However, it is recommended that the water trap is installed in a heated space below to ensure that the water in it does not freeze.

If installation problems make it impossible to secure the condensate drain pipe from freezing by insulation, it will be necessary to mount a thermostat-controlled heating tape round the condensate drain pipe.



While operating there will be a low pressure in the unit it will therefor be necessary to make sure that the height difference is min. 50 mm to the water in the siphon.



Duct system

It is recommended that the duct system is executed in spiral ducting connected with rubber ring seal fittings in order to provide a leak-free and durable duct system.

To achieve a satisfactory low sound level from the unit, sound locks must always be fitted to the supply and extract duct system between the unit and the first supply and extract fittings.

It is recommended that air speeds in the ducts are dimensioned at sufficiently low level to prevent noise from the supply and extract fittings.

When positioning fresh air and extract roof cowls/grilles, make sure the two air flows do not intercept, causing escaping air to be drawn in again.

It is recommended that grilles are placed on the north or east side of the house to provide optimum comfort.

Minimum distance: 3 m between supply and exhaust air

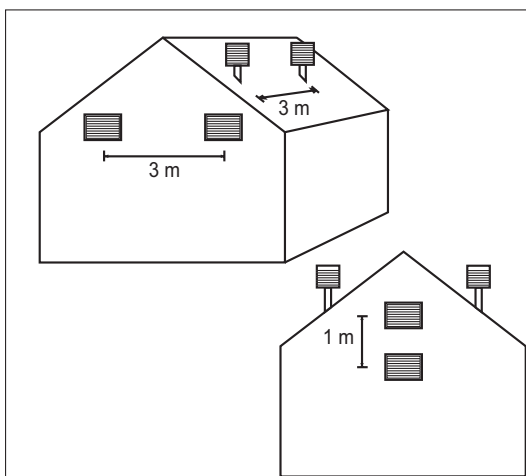

Insulation of ducts in cold loft spaces

In order to exploit the unit's high recovery potential (efficiency), it is necessary to insulate the ducts correctly.

Genvex recommends as follows:

Supply and extract ducts:

To minimise heat losses from the duct system in cold loft spaces, the supply and extract ducts must be insulated with a minimum of 100 mm insulation. If insulation form alternative A is used, it is recommended that it is executed with two layers of 50 mm lamella mats with paper or foil externally and with staggered joints between the two layers. If the ducts are laid on the rafter foot, alternative B may be used. The insulation must always be tightly packed round the ducts.

Fresh air and escaping ducts in cold spaces:

It is recommended that fresh air and escaping ducts are insulated with a minimum of 50 mm insulation. The fresh air duct is insulated to prevent warm air in the loft in summer from heating up the fresh air. Take care to seal the termination where the escaping duct is led through the roof or through the gable end, in order to avoid condensation damage.

Refer to your local distributor for guidance on national insulation directives.

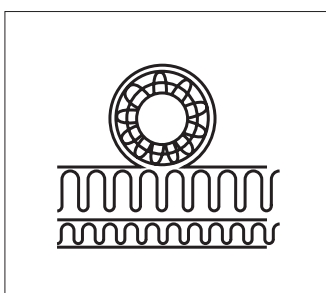

Duct insulation, alt. A

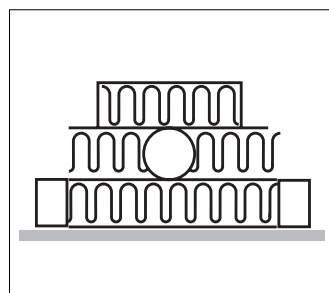

Duct insulation, alt. B

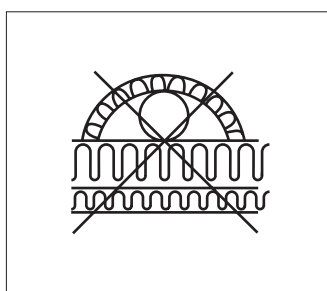

Faulty duct insulation

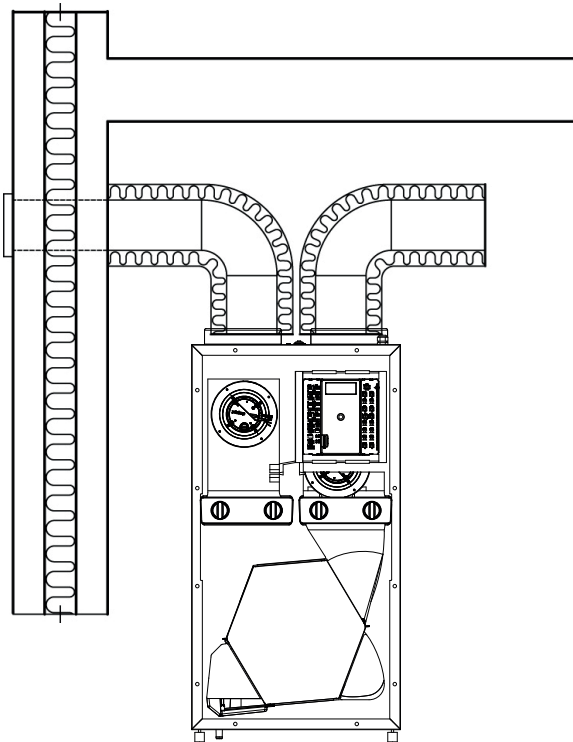

Insulation of ducts in heated spaces

Genvex recommends as follows:

Supply and extract ducts:

In warm loft spaces the supply and extract channels must be insulated with 50 mm insulation.

Supply and extract air ducts led through heated spaces in dwellings do not require insulation. If the supply air duct has cooling, bypass or earth heat exchanger installed it must be insulated.

Fresh air and exhaust ducts:

In warm loft spaces and warm rooms in dwellings the fresh and exhaust air ducts must be insulated with minimum 50 mm insulation. In addition, the insulation must be covered externally with plastic film or aluminium foil in order to avoid condensate in the insulation.

We recommend an insulation of 100 mm on the fresh air duct when installing a earth heat exchanger.

Refer to your local distributor for guidance on national insulation directives.

Reheating of supply air

As the counter current heat exchanger cannot extract all the heat from the extract air and supply it to the supply air, the supply air will be about 1-4°C colder than the room temperature in the dwelling for the whole winter season. If this lower supply temperature is insupportable during cold periods, a water-based or electrical reheating surface can be mounted for reheating the supply air up to room temperature.

Water-based reheating surface

To protect the water-based reheating surface from frost burst, a frost protection thermostat must be fitted to the unit and the surface insulated. The frost protection thermostat sensor is mounted behind the fins of the water-based reheating surface. The sensor for controlling the motor valve is mounted in the supply air channels approx. 500 mm downstream of the water-based reheating surface in order not to be affected by the radiant heat from the heating element. The water supply to the water-based reheating surface must be executed by an authorised plumbing and heating engineer.

Electrical reheating surface

The sensor for controlling the electrical heating surface is mounted in the supply air channel approx. 500 mm downstream of the electrical reheating surface in order not to be affected by the radiant heat from the heating element.

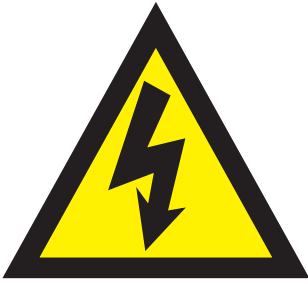

Electrical installation

The electrical connection must be carried out by an authorised electrical engineer.

See accompanying electric diagram.

The cable between the unit and the control panel is a 4-conductor cable for Optima 250, with a maximum length of 50m and a 8-conductor cable for Optima 100 with a maximum length of 10m.

Inspection and initial adjustment of appliance

To achieve optimum running of the unit it must be initially adjusted with air measuring equipment.

To start up the unit before adjustment, do as follows:

Before starting up the unit:

- 1: Check that the Genvex unit is correctly mounted and that all ducts are insulated as required.
- 2: Check that hatches can be opened so that service and maintenance on the unit can be carried out.
- 3: Check that filters are clean (may be dirty from installation work).
- 4: Check that the condensate drain is correctly mounted with water trap and is protected from freezing. Pour 1 litre water into the condensate tray and make sure it can run unhindered through the condensate drain pipe.
- 5: Set all supply valves such that the valve closest to the unit is opened three turns from closed position, while the furthest is open eight turns from closed position. Open the intermediate valves by 4-7 turns depending on how far they are from the unit.
- 6: If a reheating surface has been mounted on the unit, set the supply temperature to 0-3°C below the room temperature in the dwelling.

The unit can now be started up and be allowed to run until initial adjustment with air measurement equipment has taken place.

Optimum initial adjustment of plant

Air measuring equipment is used.

Before starting initial adjustment, check that the 6 points in the inspection and initial adjustment section have been carried out. Then start up the unit:

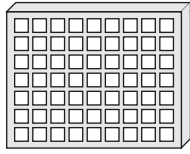

- G4 = Standard filter (Coarse filter class G4)
- F7 = Pollen filter (Fine filter class F7)

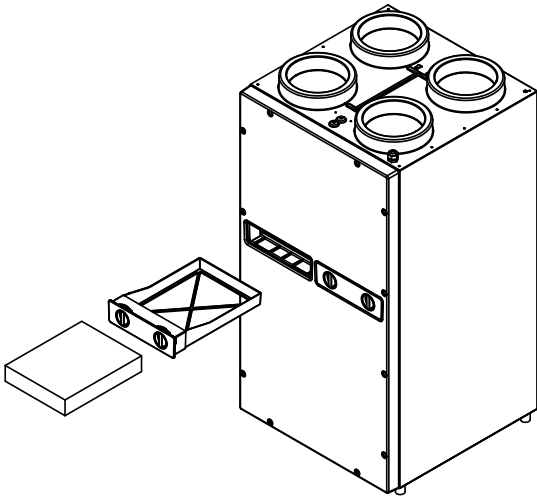

Close filter

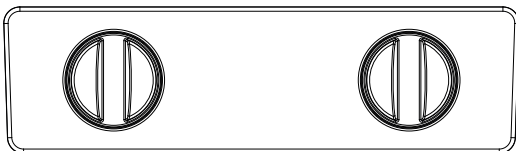

Open filter

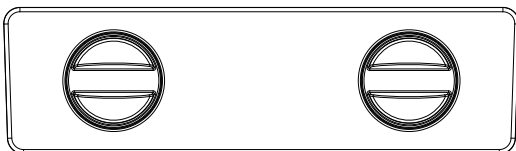

Maintenance of plant

 **Turn off the electricity for the unit before opening it**

Filters:

When the filter timer reaches the set value for filter change, "Alarm!" will show in the screen saver and "Chg. filter" will flash. This means that it is time to clean/change the filters.

Switch the unit off on the switch on the control panel or the switch on the electrical panel. Open the front doors and remove the filters. When the filters have been cleaned/replaced, close the front doors and reset the filter alarm by holding down the button below the filter symbol, until "Alarm!", "Chg. Filter" and the exclamation mark disappears in the filter symbol. The unit reverts to normal operation.

If the wish is an other time interval this can be adjust in the User menu.

The fresh air filter (F7) is in the left site of the unit and it is higher than the extract air filter (G4).

 **Do not vacuum or clean at high air pressure. It will damage the filter!**

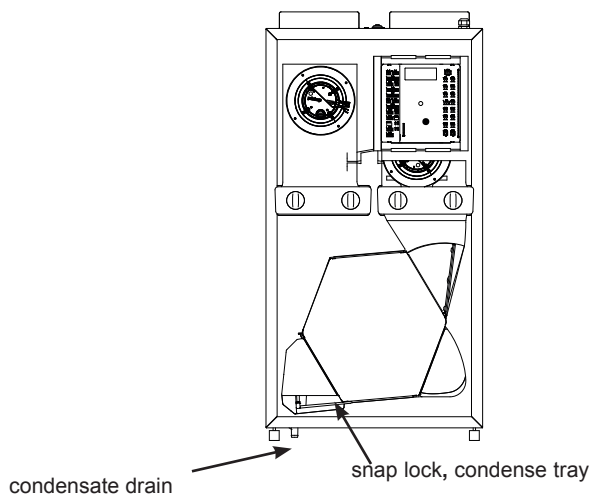

counter current heat exchanger

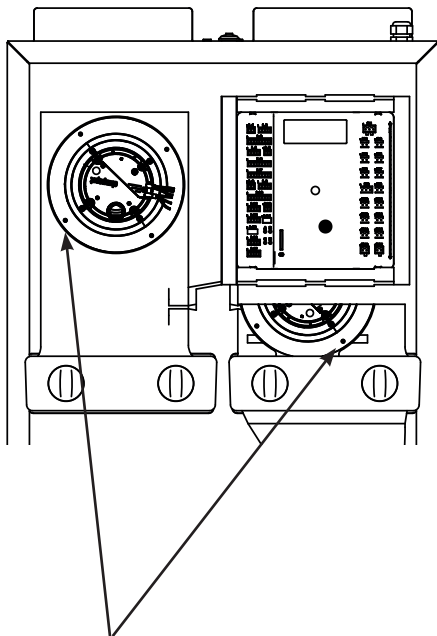
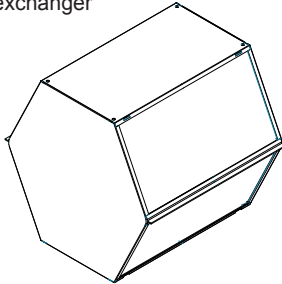

The four farest screws which are holding the fan have to be removed before the fan can be taken out.

Condensate drain:

When changing the filter in August/September, before outside temperatures falls to 5°C, check the condensate drain for blockage by dirt and check that there is water in the water trap.

Pour 1 litre water into the condensate tray and make sure it can run off without problems. If the condensate drain does not work, this could lead to water damage in the dwelling.

Countercurrent heat exchanger:

Inspect the countercurrent heat exchanger every year. If it is dirty, remove it and wash in warm soapy water and then rinse, possibly in the bathroom using the shower head. Before the counter current heat exchanger can be moved, the front of the condense tray have to be opened. There is a snap lock in the right site of the condense tray.

Fans:

Every year check the two fan wheels for dirt. If they are dirty they may be cleaned with a brush, bottle washer etc. Remember to shot down the power.

By demounting the front it is important to remove the filters before the front is removed.

Supply and extract valves:

Clean the valves by wiping with a dry cloth. Make sure the valve does not rotate, causing a change in the air volume.

Service

If you are unable to maintain your unit yourself, you can sign a service agreement with the Genvex service department. If any faults arise in the unit, contact the Genvex service department.

Troubleshooting

Safety thermostat in electrical heater (optional equipment)

If an error occurs on an electrical heater, the safety thermostat will disconnect.

The heater is equipped with a fire thermostat that automatically cuts off the power supply, if the temperature exceeds 80 °C. If the temperature decreases, the heater automatically re-engages.

As an additional security there is a built-in thermal cut-out, which disengages if the temperature exceeds 110 °C. Re-engaging must be done manually.

Does not apply to PTC electrical heaters.

The system is not running

Unit stopped

Possible error:

- Fuse in main board has blown, no power to unit.
- One of the fuses on the circuit board of the unit is blown.
- Loose wire, no power to unit.
- Loose wire between unit and control panel.
- Faulty or incorrectly set week program.
- Filter timer has switched the system off.

Condensed water is leaking from the unit

Possible error:

- Condensation outlet blocked by dirt.
- The condensation outlet is not adequately protected against freezing at low outdoor temperatures.

Air faults

No supply air:

Possible error:

- Faulty supply air fan
- Clogged supply air filter
- Clogged fresh air grill due to dirt and leaves during the fall and snow and ice during the winter.
- Fuse on the circuit board is blown.
- The unit is in defrost mode (supply air fan stops)
- Incorrect value set in User menu item 2.

No extract air:

Possible error:

- Faulty extract air fan
- Clogged extract air filter.
- Fuse on the circuit board is blown

Cold supply air:

Possible error:

- Clogged heat changer.
- Faulty extract air fan.
- Clogged extract air filter.
- Electrical reheater is disconnected at the over heat-

ing thermostat (only units with electrical reheater installed).

- Air in the heating pipes, faulty thermostat / motorvalve, incorrect setting of control panel.

Within the guarantee period (0-2 years):

The installer from whom you have bought the system.

After the guarantee period (2 years ->):

The installer from whom you have bought the system or the Genvex service department (+45 7353 2765).

Before calling, please write down the data from the inscription plate (silver plate on the unit).

Alarms

Filter timer

The control has a filter timer to guarantee that the filter is changed and that optimal operation is established. When the timer reaches the set value, "Chg. filter" will flash in the display until the filters have been changed.

When the filters have been changed, the button for the filter symbol must be held down until "Alarm!", "Chg. Filter" and the exclamation mark disappears and the unit reverts to normal operation.

Com error

This error appears when there is no communication between the display and control. Check that the wiring is correct on terminals 21 to 24.

21	Signal
22	Signal
23	10 Volt
24	0 Volt

Frost protection error

This error message will be displayed if a water reheater is fitted to the system and the temperature of the water reheater is too low, causing a danger of frost burst.

The control will stop the system and open the motor-operated valve to keep the heater warm.

PCB **ES960** for Optima 250 Design

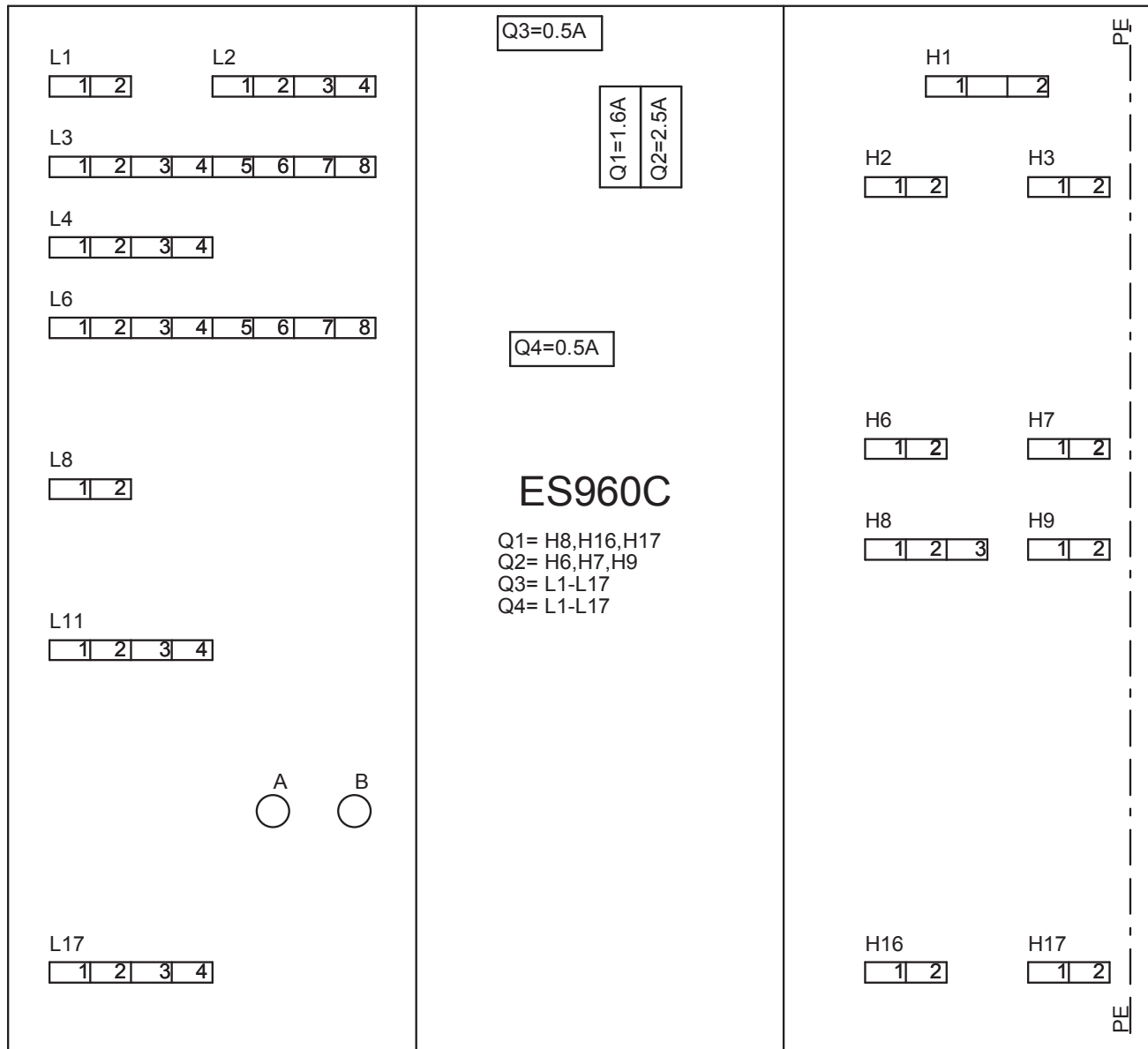

Q=Fuse

L1 =Humidistat
 L2 =Display
 L3 =Sensors T1,T3,T4,T7
 L4 =Humidity sensor P1
 L6 =Sensors T8,T9
 L8 =External stop
 L11=0-10V Water valve and
 0-10V Belimo bypass
 L17=0-10V extract air fan and
 0-10V supply air fan

H1 =Mains connection 230 VAC
 H2 = (R2) Electric Reheater 230VAC
 H3 = (R3) Electric Preheater 230VAC
 H2,H3 =Max. load total 1800W COSΦ1
 H6 = (R10) Water valve, Belimo Bypass 230VAC
 H7 = (R10) Fan, extract air 230VAC
 H8 = (R12) ON/OFF Bypass 2x230VAC
 H9 = (R10) Fan, supply air 230VAC/bypass
 H16= (R8) AUX relay 230VAC max. 20W
 H17= (R9) AUX relay 230VAC max. 20W

Wiring Diagram Optima 250 Design with ES960 PCB

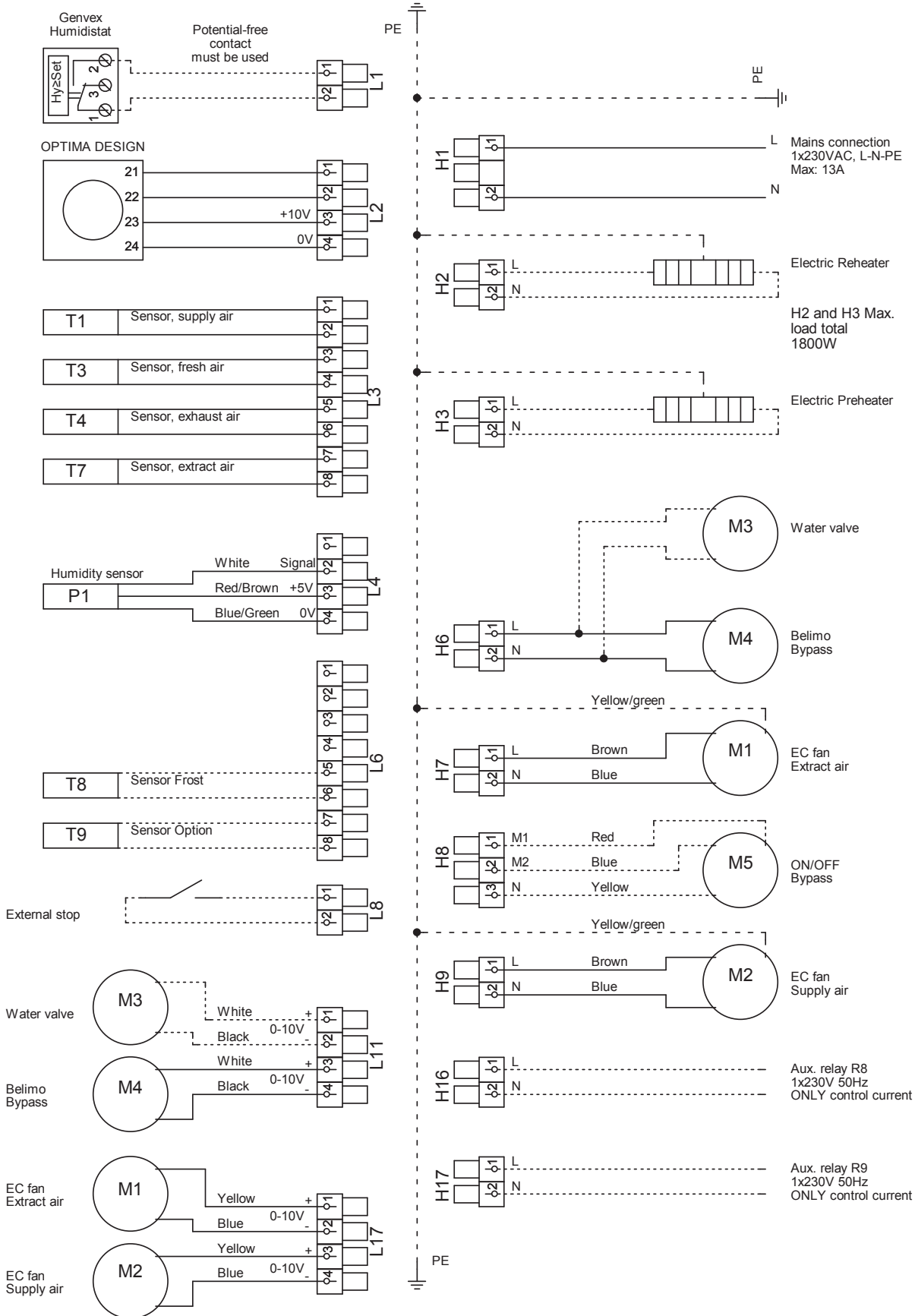

PCB ES951 and Wiring Diagram for Optima 100 Design

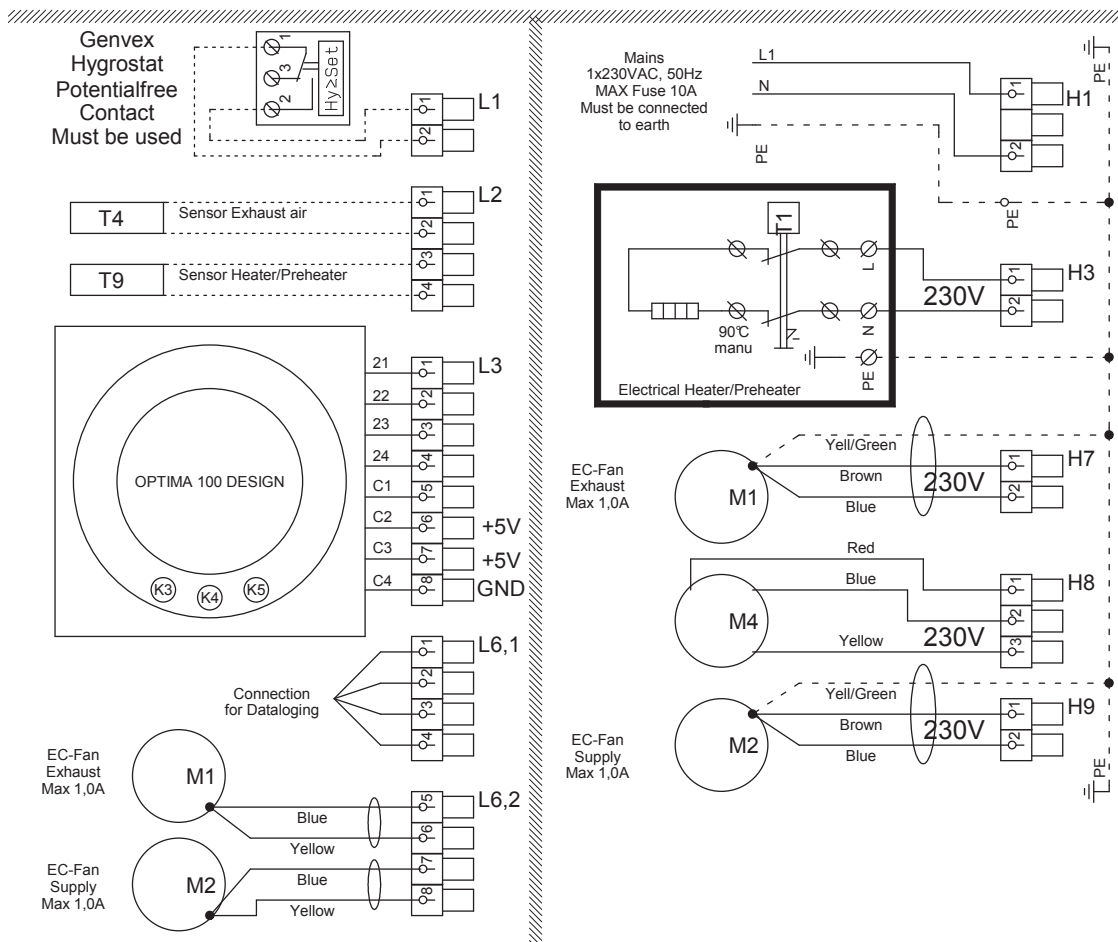
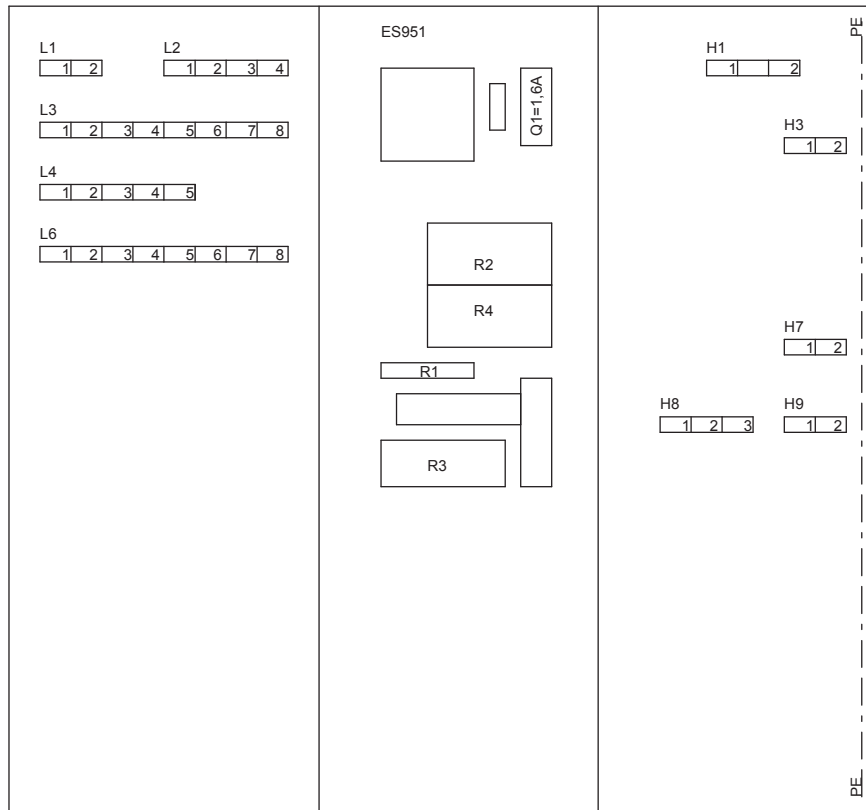



EF - Overenstemmelseserklæring
EC - Declaration of Conformity
EG - Konformitätserklärung



A. Fabrikant :
Manufacturer :
Herst ller :

Genvex A/S
Sverigesvej 6
DK-6100 Haderslev
+45 73 53 27 00
Salg@genvex.dk
www.genvex.dk

Erkl rer hermed, at f lgende produkt / hereby certifies that the following product / best tigt, da das nachfolgend bezeichnete Ger t:

B. Ben vnelse : **GES Energy S / M Ventilation Passiv**
Type : **GES Energy S / M Ventilation Passive**
Typ: : **GES Energy S / M Ventilation Passive**

C. Hoved Nr : 010301, 010302, 010303, 010304, 010305, 010311, 010312, 010313, 010314, 010315
Serie No. : 010316, 010321, 010322, 010323, 010324, 010325, 010331, 010332, 010333, 010334,
010335, 010342, 010343, 010344, 010345, 010350, 010351, 010352, 010353, 010354,
010355, 010356, 010357, 010360, 010361, 010362, 010363, 010364, 010365, 010372,
010373, 010374, 010375, 010382, 010383, 010384, 010385, 010386, 010387, 010388,
010414, 010455

Ved foruds tning af at Genvex's montageanvisninger er fulgt / on the assumption that the mounting instructions from Genvex have been followed / bei Voraussetzung dass die Montageanweisungen von Genvex gefolgt wurden.

Er fremstillet i overensstemmelse med / is made according to /
 ber Einstimmung von nachfolgend bezeichnete EG-Sicherheitsstandards hergestellt:

Directive:

- R dets direktiv 2006/42/EF (Maskindirektivet), EU-Directive 2006/42/EC; EG-Maschinenrichtlinie 2006/42/EG
- R dets direktiv 2006/95/EF (Lavsp ndingsdirektivet) af 12. december 2006. EU-Directive 2006/95/EC, EG-Niederspannungsrichtlinie 2006/95/EG
- R dets direktiv 2004/108/EF (EMC-Direktivet) af 15. december 2004, EU-Directive 2004/108/EC,
- R dets direktiv 99/5/EF af 9 marts 1999; EG-EMV-Richtlinie 2004/108/EG af den 15. december 2004
- R dets direktiv 2011/65/EU af 8. juni 2011 RoHS

Departmental Order.

- No. 797 17. august 2009
- LBK nr. 823 af 3. juli 2007
- No. 743 af 23. september 1999
- AT No. 612 af 25. juni 2008.

DS/EN

- 60335-1-A13-A14 General requirements
- 60335-2-40 Particular requirements for electrical heat pumps, air-conditioners and dehumidifiers
- 55014-1 Electromagnetic compatibility Part 1: Emission
- 55014-2 Electromagnetic compatibility Part 2: Immunity

Virksomhed: Company: Firma:	Sted og dato: Place and date: Ort und Datum:	Underskrift: Signature: Unterschrift:
Genvex A/S Sverigesvej 6 DK-6100 Haderslev	Haderslev, 14. Jan 2014	 Torben Thomsen (R&D Manager)
		 Johann P. Nicolaisen (Quality Assurance)



EF - Overensstemmelseserklæring
EC - Declaration of Conformity
EG - Konformitätserklärung



Genvex

A. Fabrikant :
 Manufacturer :
 Hersteller :

Genvex A/S
 Sverigesvej 6
 DK-6100 Haderslev
 +45 73 53 27 00
 Salg@genvex.dk
 www.genvex.dk

Erklærer hermed, at følgende produkt / hereby certifies that the following product / bestätigt, da das nachfolgend bezeichnete Gerät:

B. Benævnelse : **Energy ECO 180 Ventilation Passiv**
 Type : **Energy ECO 180 Ventilation Passive**
 Typ: : **Energy ECO 180 Ventilation Passive**

C. Hoved Nr : 010600, 010601, 010602, 010603, 010604, 010605, 010606, 010607
 Serie No. :

Ved forudsætning af at Genvex's montageanvisninger er fulgt / on the assumption that the mounting instructions from Genvex have been followed / bei Voraussetzung dass die Montageanweisungen von Genvex gefolgt wurden.

Er fremstillet i overensstemmelse med / is made according to / über Einstimmung von nachfolgend bezeichnete EG-Sicherheitsstandards hergestellt:

Directive:

- | | |
|----------------------------------|-------------------------------|
| a) Machinery | 2006/42/EC 15. March 2006 |
| b) Low Voltage | 2006/95/EU 12. December 2006 |
| c) Electromagnetic Compatibility | 2004/108/EC 15. December 2004 |
| d) Radio/Telecommunication | 99/5/EC 9. March 1999 |
| e) RoHS | 2011/65/EU 8. June 2011 |

Departmental Order.

- a) No. 797 17. august 2009
- b) LBK nr. 823 af 3. juli 2007
- c) No. 743 af 23. september 1999
- d) AT No. 612 af 25. juni 2008.

DS/EN

- a) 60335-1-A13-A14 General requirements
- b) 60335-2-40 Particular requirements for electrical heat pumps, air-conditioners and dehumidifiers
- c) 55014-1 Electromagnetic compatibility Part 1: Emission
- d) 55014-2 Electromagnetic compatibility Part 2: Immunity

Virksomhed: Company: Firma:	Sted og dato: Place and date: Ort und Datum:	Underskrift: Signature: Unterschrift:	
Genvex A/S Sverigesvej 6 DK-6100 Haderslev	Haderslev, 19. jun 2014	 Torben Thomsen	 Johann P. Nicolaisen
		(R&D Manager)	(Quality Assurance)

Our Units and Controls – Your Choice

Genvex has more than 40 years of experience in creating quality units providing optimum indoor climate with excellent energy efficiency. Our systems employ the newest technologies in heat recovery and have heat recovery rates of up to 96%. The systems are continuously optimised with the newest technologies.

Advanced controls ensure that as little energy as possible is used for reaching an optimum level of comfort.

Today's and future construction place greater and greater requirements for energy-friendly, yet compact systems. We at Genvex are aware of this and are continuously developing solutions that meet these needs. For example, a brilliant solution for decentralised housing ventilation is a range hood solution with full integration to the system's control which ensures that the most efficient ventilation system is achieved with the simplest installation.

